

FIG. 3

- Place footings so that the center line of the posts will be 3' outside the court on each side. The center lines of posts should be positioned 42' apart for Doubles court (FIG. 3) and 33' apart for Singles court.



FIG. 4

- Install pipe anchor: making sure the anchor is installed flush with the surface and that the pin is parallel to the net line to avoid twisting the center strap.
- Begin installing your net by hooking the loop end of the tennis net cable to the cable cleat on the deadhead post (FIG.4), On the winder head post (FIG.5), take the other end of the cable and hook the loop onto the pin on the reel assembly and begin winding. Continue to crank the post so that the net is a little over 3' above the surface at the center. *Be careful not to over-tighten!* Fit dowels/side stakes if available into side pockets of the net.

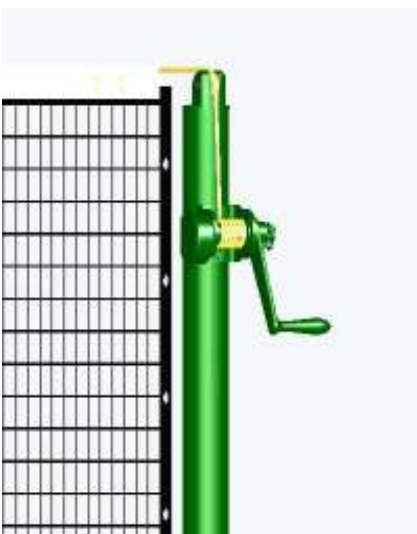

FIG.5

Continued

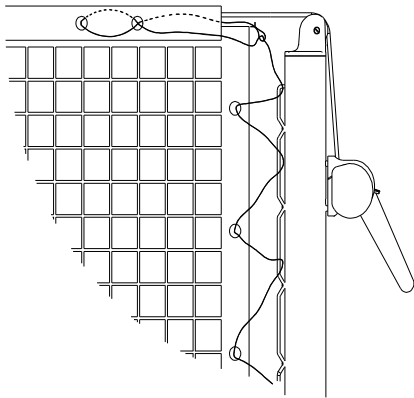

FIG. 6

6. Install lacing cord at each end by making a 2" knotted loop on one end of the lacing cord. Run the other end through both grommets in the tennis net headband and around the post, through the 2' loop and back around the post in the opposite direction. (FIG. 6)

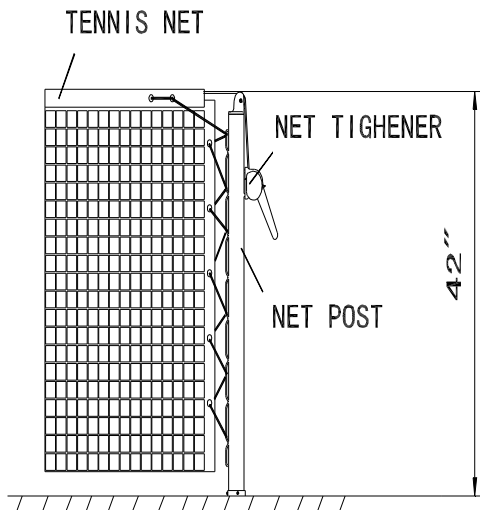

FIG. 7

7. Continue wrapping the cord around the post, through the lacing bars and through the grommets on the tennis net side band, applying equal pressure as you wrap. Tie off the cord at the bottom of the post. Repeat for other post. FIG. 7 shows a properly laced net. Install center strap and adjust it to maintain a net height of 36" at center.

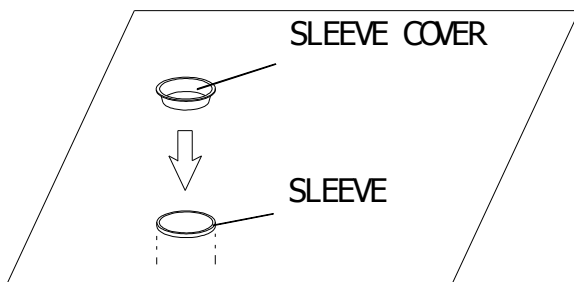

FIG. 8

8. Use the enclosed sleeves for easy removal of posts for resurfacing, maintenance, posts repair or replacement, and alternate uses of the court. During the off season or when winterizing, it is best to remove net posts and plug the sleeves with sleeve covers to prevent moisture and dirt from falling in. (FIG. 8)