

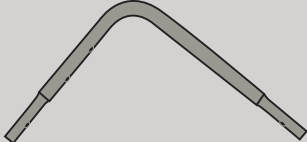

1  Straight tube 60" long with a single hole in each end. X 4PCS

2  L shape corner tubes 14" long with 2 holes and snap pin. 26" long. Other end with snap pin only. X 4 PCS

3  Stand legs with 90° bend on each end. (One end has two holes). X 4 PCS

4  2" Tilt extension for legs. X 2 PCS

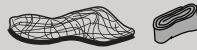
5  223W Net and 3511W Net Height Tape

210W = Springs. X 36 PCS + "S" Hooks. X 36 PCS +

6  "S" Hooks. X 36 PCS +

Rubber Leg Caps. X 4 PCS +

7  Rubber Leg Caps. X 4 PCS +

1/4"x 2-1/2" bolts with nuts. X 4 PCS

8  1/4"x 2-1/2" bolts with nuts. X 4 PCS

STEP 1

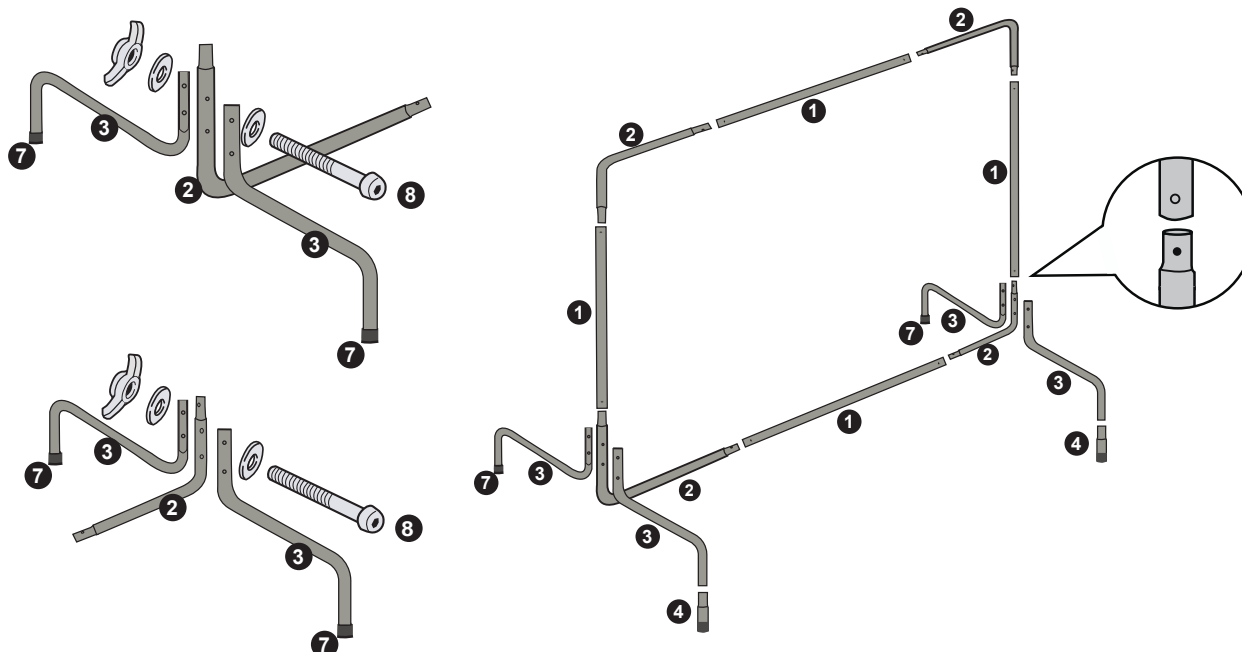

Using part list, identify each tubular part & lay out as shown. Assemble the frame as indicated in the drawing. Attach rubber leg caps on the bottom of the stand legs. For tilt adjustment to practice "lobs", remove two rubber caps and install the extension.

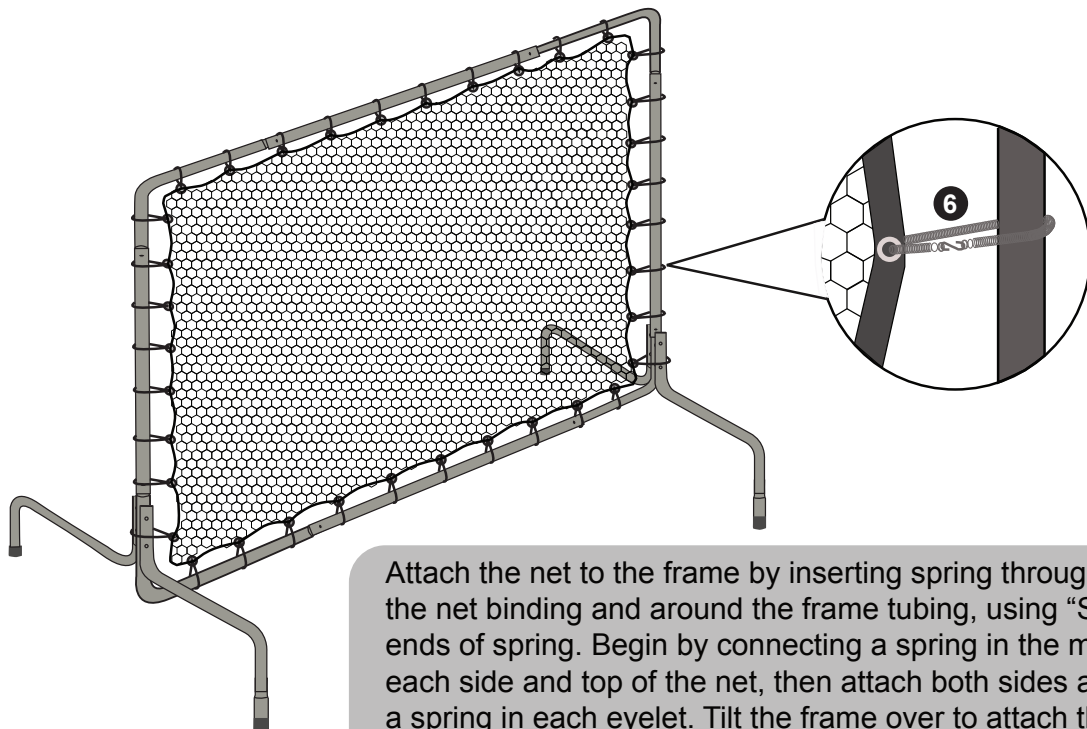

Attach the net to the frame by inserting spring through the eyelets in the net binding and around the frame tubing, using "S" hook to connect ends of spring. Begin by connecting a spring in the middle eyelet in each side and top of the net, then attach both sides and the bottom with a spring in each eyelet. Tilt the frame over to attach the top of the net.

If your net hangs too loosely on the frame, substitute 3510W Shorter Springs and "S" hooks on one side (left or right) and top (or bottom). This will make net more taut.

STEP 3

Thread 3511W Net Height Tape through the net approximately 3 feet from the floor surface to simulate the top of a tennis net.

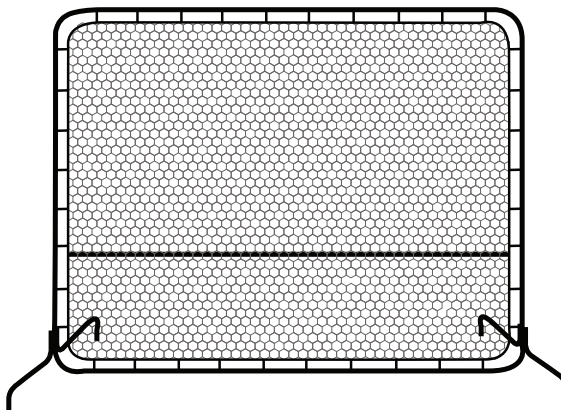

Replacement Parts are available:
 210W - Springs, "S" Hooks, Nuts, Bolts, Rubber Leg Caps
 223W - Net
 3510W - Short Springs + "S" Hooks X 18 PCS
 3511W - Net Height Tape